

ALLOWABLE ROTATION
TOP VIEW
SCALE 1:2

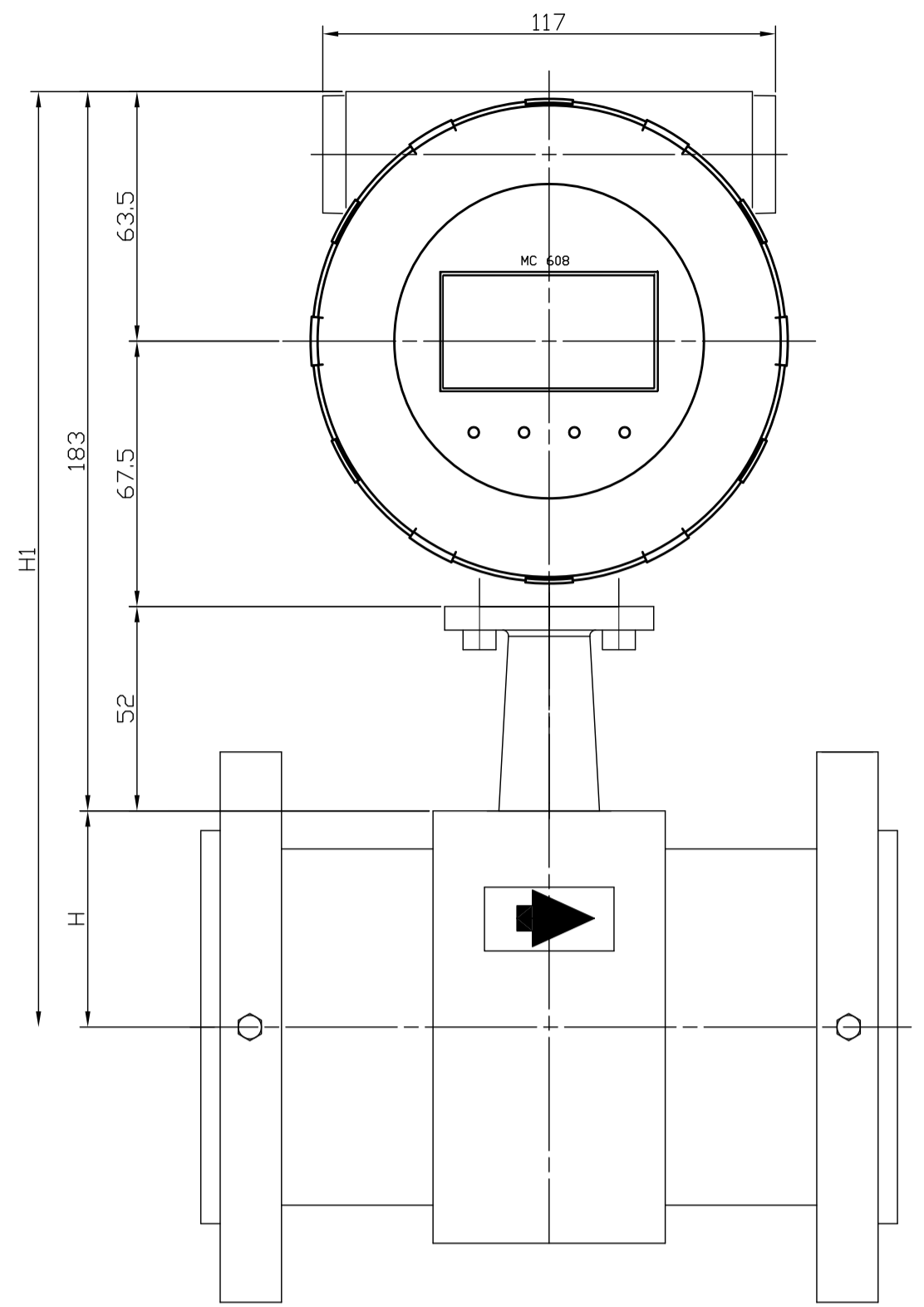
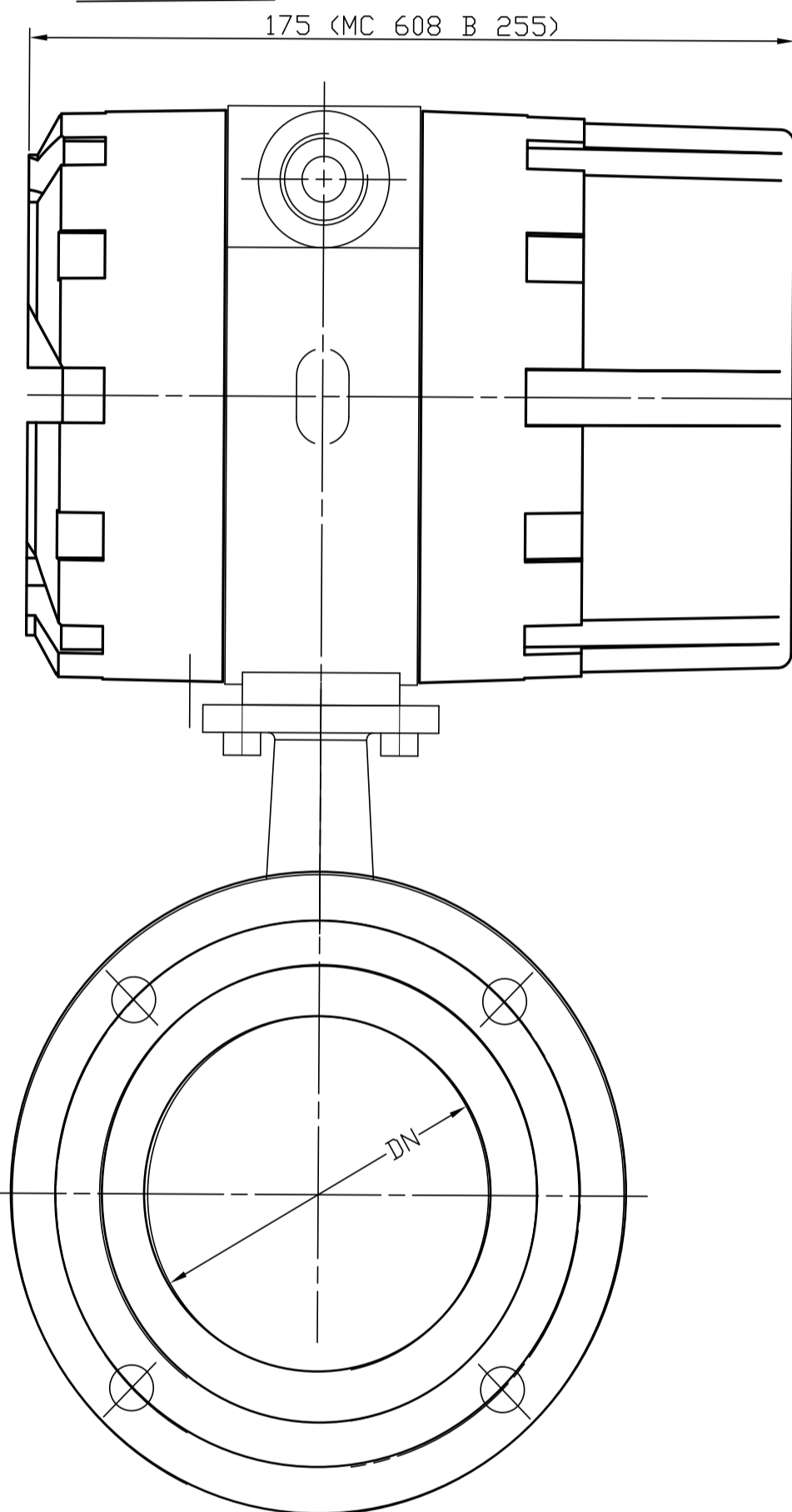

	DN	H	H1
MUT 2200 EL	25	32	215
	32	38.5	221.5
	40	41	224
	50	49	232
	65	57	240
	80	63.5	246.5
	100	76	259
	125	89	272
	150	103	286
	200	128.5	311.5
MUT 2500 EL	250	155.5	338.5
	300	181	364
	350	197	380
	400	222	405
	450	259.5	442.5
	500	285	468
	600	341	524
	700	391.5	574.5
	800	442.5	625.5
	900	498	681
1000	549	732	
1200	656	839	
1400	756	939	
1500	808	991	
1600	856	1039	
1800	961	1144	
2000	1061	1244	

DESCRIPTION

GENERAL ASSEMBLY
MUT 2200 EL / MUT 2500 EL COMPACT
MC 608

SCALE N/A	FORMAT A2	PART N°		PREPARED BY L.V	DATE 11/01/11
MATERIAL		WEIGHT [kg]		APPROVED BY F.T.	DATE 11/01/11
SURFACE TREATMENT		PAGE 1	OF 1	DRAWING N° D-05725-0	REV 0



REV. 12/2018

RevNo Revision note Date Signature Checked