



Valvola a sfera a DUE vie
 Organo di comando:
 Flangia per Attuatore ISO
 5211 - DIN 3337
 Attacco: Flange filettate
 girevoli UNI EN 1092-
 1:2003
 Passaggio: Totale
 Materiale: Aisi 304 - 316
 Misure: da DN 10 a DN
 100
 Guarnizioni di tenuta:
 P.T.F.E. vergine
 Temperatura di esercizio: -
 20°C +160°C
 Finitura esterna: Lucida

A richiesta:

- Flange in acciaio zincato
- Flange ANSI 150
- Flange ANSI 300

- Guarnizioni di tenuta in:
 PTFE caricato vetro
 PTFE caricato carbografite
 Polietilene ad alta densità

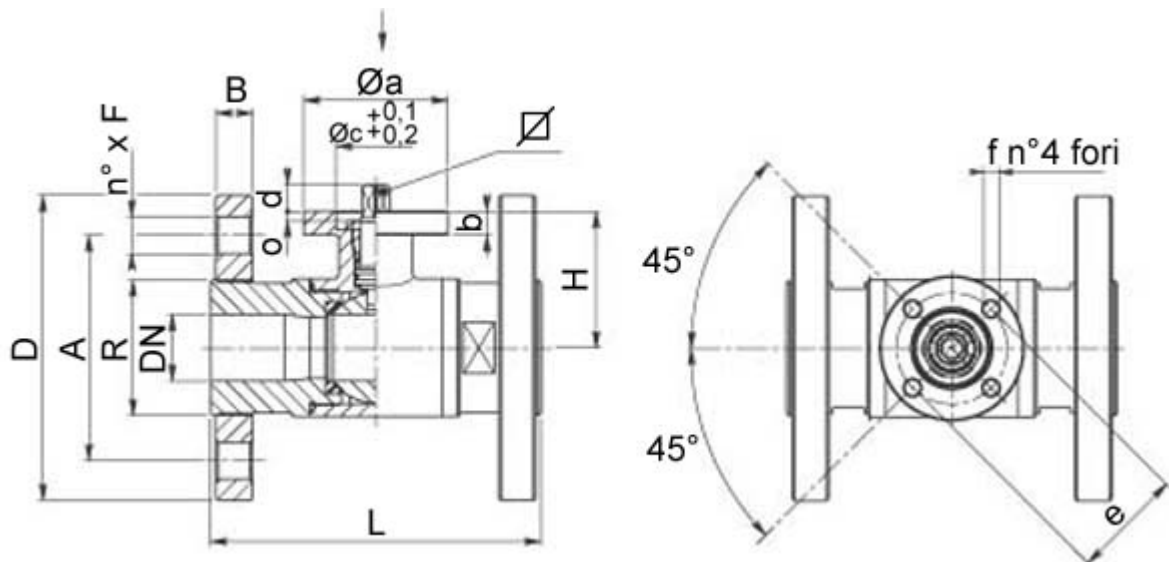

DN	L	H	E	D	B	R	A	n° x F	PN	Kg	ISO- DIN	Ø a	b	Ø c x o	□	d	E	f	n°4 viti	Nm *
10	110	39	90	12	30	60		4 x 14	40	1,60	F.03	46	9	25x3	9	8	36	6	M5x16	5
10	110	39	90	12	30	60		4 x 14	40	1,65	F.04	54	9	30x3	11	10	42	6	M5x16	5
15	115	41,5	95	12	35	65		4 x 14	40	1,80	F.03	46	9	25x3	9	8	36	6	M5x16	8
15	115	41,5	95	12	35	65		4 x 14	40	1,83	F.04	54	9	30x3	11	10	42	6	M5x16	8
20	120	45	105	14	42	75		4 x 14	40	2,53	F.03	46	9	25x3	9	8	36	6	M5x16	12
20	120	45	105	14	42	75		4 x 14	40	2,65	F.04	54	9	30x3	11	10	42	6	M5x16	12
25	125	51,5	115	14	51	85		4 x 14	40	3,40	F.04	54	9	30x3	11	10	42	6	M5x16	15
25	125	51,5	115	14	51	85		4 x 14	40	3,45	F.05	65	9	35x3	14	13	50	7	M6x16	15
32	130	56,5	140	16	63	100		4 x 18	40	4,98	F.04	54	9	30x3	11	10	42	6	M5x16	18
32	130	56,5	140	16	63	100		4 x 18	40	5,04	F.05	65	9	35x3	14	13	50	7	M6X16	18
40	140	76	150	16	75	110		4 x 18	25	6,35	F.05	65	12	35x4	14	13	50	7	M6x20	25
40	140	76	150	16	75	110		4 x 18	25	6,52	F.07	90	12	55x4	17	15	70	9	M8x20	25
50	150	84	165	18	89	125		4 x 18	25	8,90	F.05	65	12	35x4	14	13	50	7	M6x20	30
50	150	84	165	18	89	125		4 x 18	25	9,15	F.07	90	12	55x4	17	15	70	9	M8x20	30
65	170	94,5	185	18	110	145		4 x 18	16	13,96	F.07	90	12	55x4	17	15	70	9	M8x20	45
65	170	94,5	185	18	110	145		4 x 18	16	14,46	F.10	125	12	70x4	22	18	102	11	M10x25	45
65	170	94,5	185	20	110	145		8 x 18	25	-	F.07	90	12	55x4	17	15	70	9	M8x20	45
65	170	94,5	185	20	110	145		8 x 18	25	-	F.10	125	12	70x4	22	18	102	11	M10x25	45

80	180	106	200	18	120	160	8 x 18	16	16,10	F.07	90	12	55x4	17	15	70	9	M8x20	70
80	180	106	200	18	120	160	8 x 18	16	16,60	F.10	125	12	70x4	22	18	102	11	M10x25	70
100	190	120	220	20	140	180	8 x 18	16	22,00	F.07	90	12	55x4	17	15	70	9	M8x20	80
100	190	120	220	20	140	180	8 x 18	16	22,50	F.10	125	12	70x4	22	18	102	11	M10x25	80

Note tabella:* Max spunto di apertura in Nm

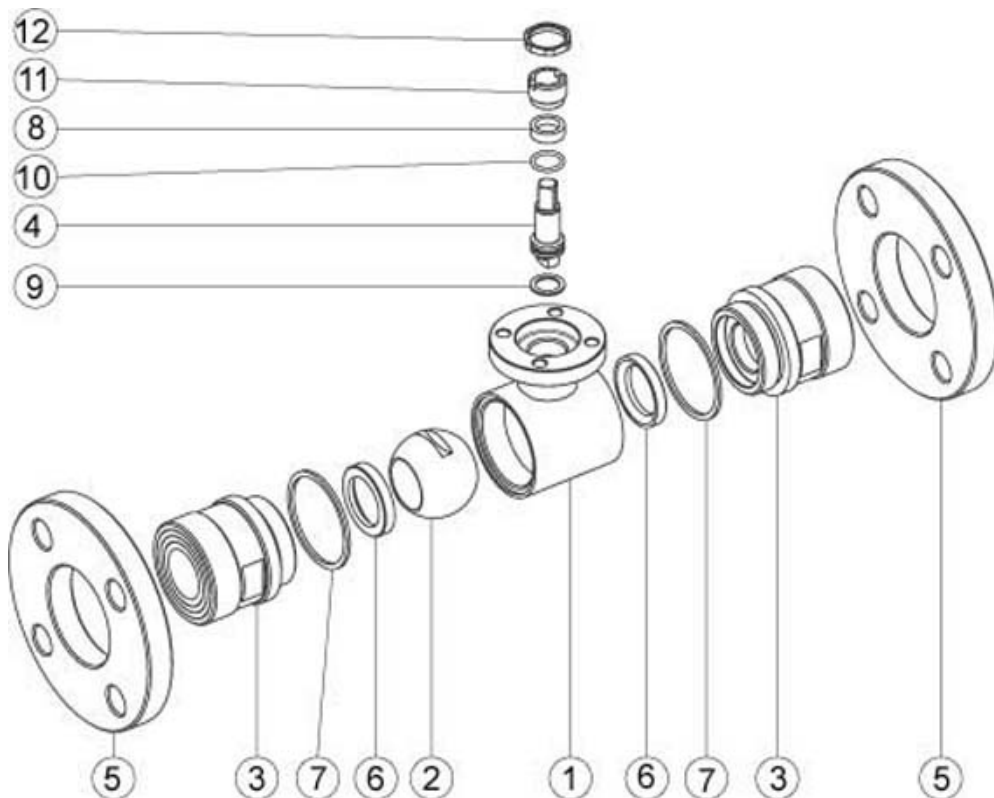

Pos.	Denominazione	P.zi	Mat.
1	Corpo	1	AISI 304 - 316
2	Sfera	1	AISI 304 - 316
3	Manicotti	2	AISI 304 - 316
4	Perno	1	AISI 304 - 316
5	Flange	2	AISI 304 - 316 - Aq
6	Guarnizioni sfera	2	PTFE
7	Guarnizioni manicotti	2	PTFE
8	Guarnizione perno	1	PTFE
9	Guarnizione perno	1	PTFE
10	OR di tenuta perno	1	FKM (Viton)
11	Ghiera di registro	1	AISI 304 (303)
12	Controdado	1	AISI 303

